

For full product information, visit www.sti.com. Use the SpeedSPEC Code for quick access to the specific web page.

Perimeter Access Guarding Device

- 1 to 6 beams available
- Operating range of 70 m
- Compact size — 46 x 55 mm (1.81 x 2.17 in.)
- Simple “two-box” design — no separate control box required
- Individual Beam Indicators
- A Rapid Delivery Product: Select models are available for shipment today or within 3 to 5 days



C

Specifications

Performance	
Protective Height:	Variable
Operating Range:	0.8 to 70 m
Response Time:	Transmit Code A: <24 ms; Transmit Code B: <20 ms; Transmit Code C: <16 ms
Electrical	
Input Voltage (V _{in}):	24 VDC ± 20%
Input Power:	8.4 watts (without load on the outputs)
Safety Output Ratings:	Two PNP outputs sourcing 625 mA max @ V _{in} (see note 1). Short circuit protected.
Auxiliary (non-safety) Output Rating:	One NPN output sinking 100 mA max @ V _{in} or one PNP output sourcing 100 mA @ V _{in} (see notes 1 and 2)
Power Supply:	24 VDC ± 20%. The rating depends on the current requirement of the loads attached to the outputs (see note 3). The power supply must meet the requirements of IEC 60204-1 and 61496-1. STI part number 42992 or equivalent.
External Device Monitoring:	50 mA @ 24 VDC steady state
Start/Restart:	N.O. input. Momentary contact (10 mA consumption)
Effective Aperture Angle:	± 2.5° maximum, transmitter and receiver at operating range greater than 3 m per IEC 61496-2
Light Source:	Infrared light emitting diode, 880 nm
Transmitter Indicator Light:	Active (yellow)
Receiver Indicator Lights:	Machine run (green), machine stop (red), interlock/fault (yellow), individual beams and two 7-segment displays (red)
Mechanical	
Construction:	Polyester powder-painted aluminum
Cable Length:	Available in 10, 15 and 30 m lengths, unshielded.
Minimum Cable Gauge:	22 AWG (0.32 mm ²) for user-supplied cables
Cable Connections:	8-pin terminal block Optional Receiver Connector: M-12, 8-pin connector Optional Transmitter Connector: M-12, 5-pin connector
Environmental	
Enclosure Rating:	IP67
Operating Temperature:	0 to 55°C (32 to 131°F)
Relative Humidity:	95% maximum, non-condensing
Vibration:	5-60 Hz maximum on all 3 axis
Shock:	10 g of 0.016 seconds; 1,000 shocks for each axis on two axis
Approvals	ESPE Type 4 (IEC 61496-1/ -2) Category 4 / PL e (EN ISO 13849-1) SIL3 / SIL3 CL3 (IEC 61508 / EN 62061) UL508, UL1998, CAN/CSA-C22.2 No. 14, CAN/CSA-C22.2 No. 0.8, CAN/CSA-C22.2 No 0, CAN/CSA-C22.2 No 205



Description

The Perimeter Access PA4600 is a long-range, multi-beam safeguarding device. It is suited to detect the torsos of personnel entering a hazardous area. Installation and alignment is simplified with Individual Beam Indicators, which glow red when the beam is out of alignment or blocked. The separate Scan Codes allow the installer to select unique scan frequencies that eliminate cross-talk with adjacent PA4600 systems. Diagnostics are greatly enhanced with the LED status indicators and numeric displays.

Specifications subject to change without notification.

Note 1: Voltage available at the outputs is equal to V_{in} - 2.0 VDC.

Note 2: Total current required by the two solid-state outputs and the aux. output should not exceed 1.35 A.

Note 3: Total system current requirement is the sum of the transmitter 100 mA and receiver 1.6 A max. (receiver 250 mA + OSSD1 load + OSSD2 load + aux. output load)

Select models are available for Rapid Delivery.

Visit this product on www.sti.com for details.

Dimensions

(mm/in.)

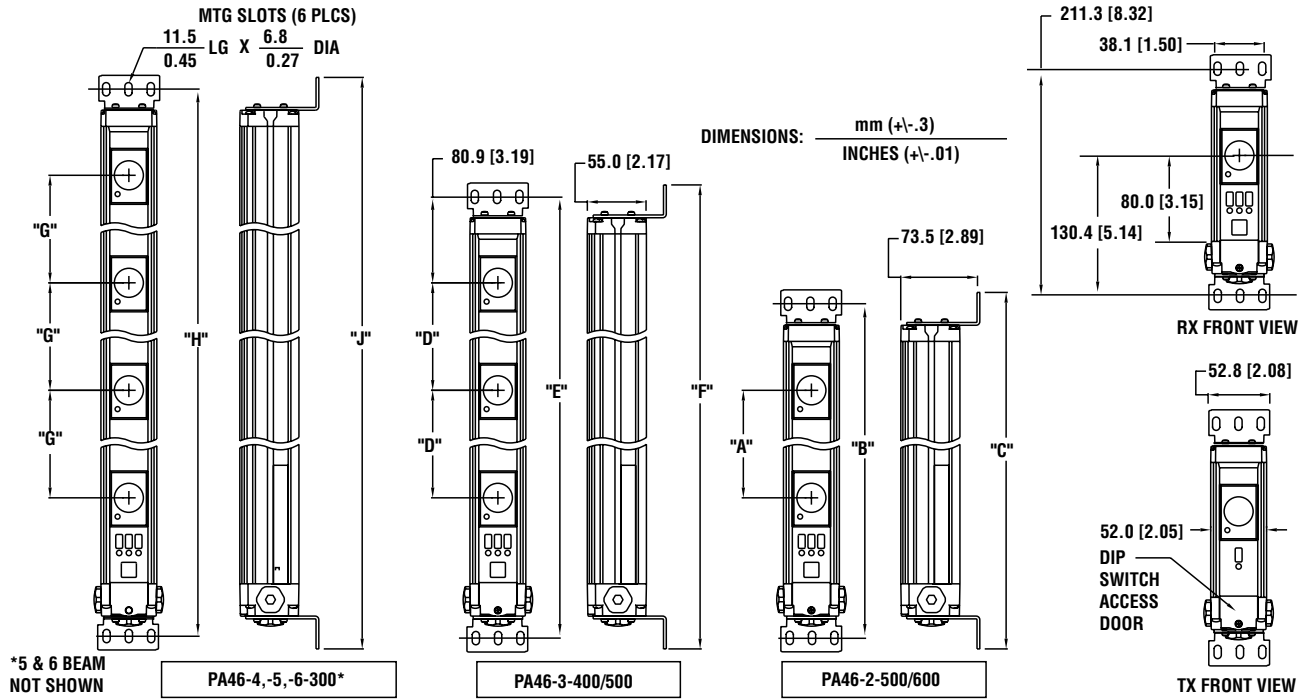

PA4600 Dimensions and Shipping Weights

	Beam Spacing mm/in.	Mounting Holes mm/in.	Overall Height mm/in.	System Shipping Weights kg/lb.
PA46-1-000	N/A	211.3/8.32	231.6/9.12	4.5/10
PA46-2-500**	A = 500/19.69	B = 711.3/28.00	C = 731.6/28.80	6.3/14
PA46-2-600*	A = 600/23.62	B = 811.3/31.94	C = 831.6/32.74	6.7 /15
PA46-3-400**	D = 400/15.75	E = 1011.3/39.81	F = 1031.6/40.61	7.2 /16
PA46-3-500*	D = 500/19.69	E = 1211.3/47.68	F = 1231.6/48.49	8.6/19
PA46-4-300**	G = 300/11.81	H = 1111.3/43.75	J = 1131.6/44.55	8.2 /18
PA46-5-300	G = 300/11.81	H = 1411.3/55.56	J = 1431.6/56.36	9.5/21
PA46-6-300	G = 300/11.81	H = 1711.3/67.37	J = 1731.6/68.17	10.4/23

*Meets ANSI/RIA R15.06-1999 (R2009)

**Meets EN999: 1998

Select models are available for Rapid Delivery.

Visit this product on www.sti.com for details.



Wiring

Connecting to Machine Control System Via Two Force-Guided Relays

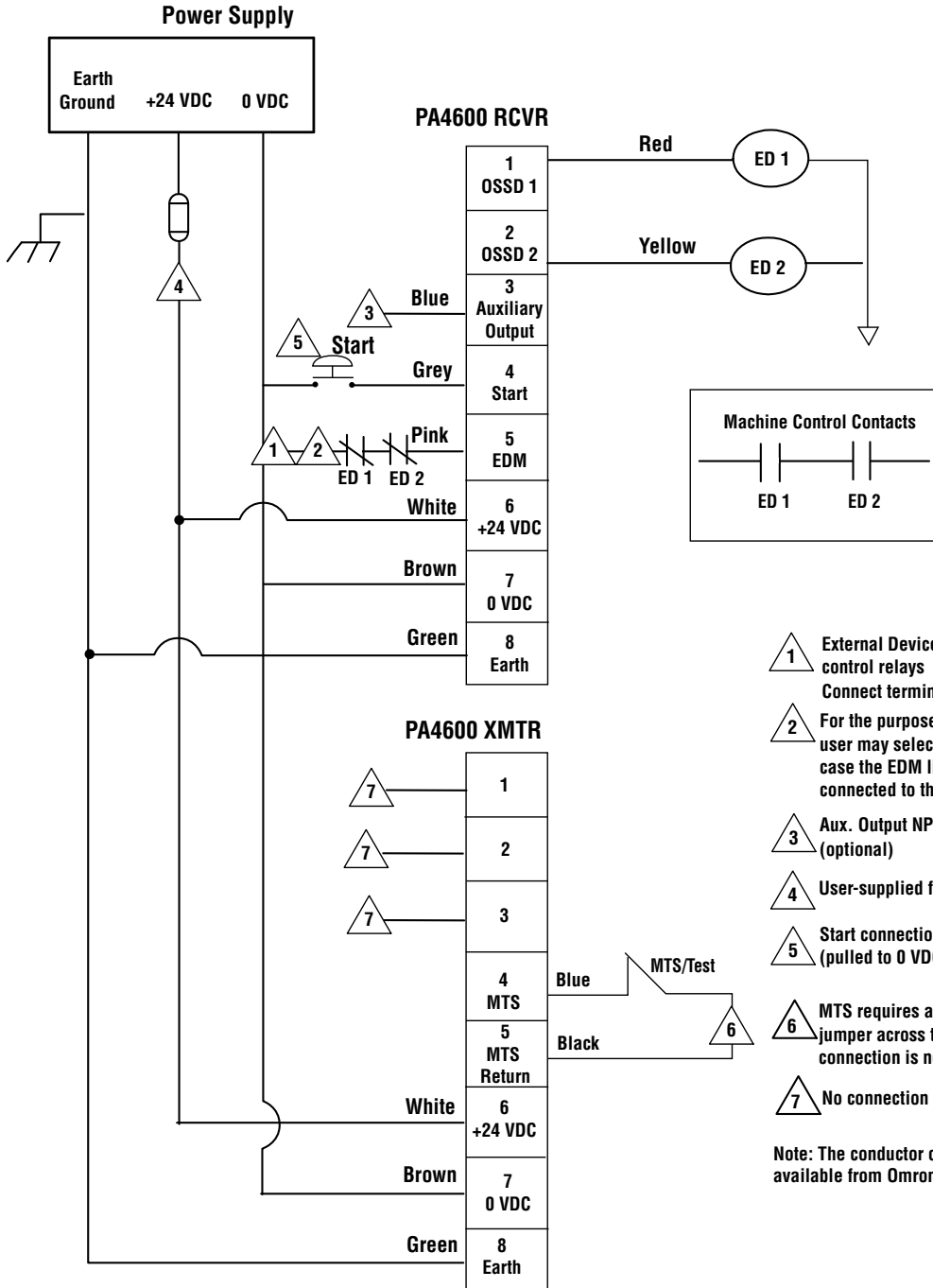

- 1 External Device Monitoring must be used when force-guided control relays are used as the Final Switching Devices. Connect terminal 5 (pink wire) through N.C. contacts to 0 VDC.
- 2 For the purpose of bench testing prior to installation, the user may select EDM OFF (default factory setting). In this case the EDM line, terminal 5 (pink wire) must be connected to the 0 VDC line.
- 3 Aux. Output NPN or PNP 100 mA. max. @ 24VDC, connect to PLC (optional)
- 4 User-supplied fuse
- 5 Start connections are shown with option NO1 – normally open (pulled to 0 VDC)
- 6 MTS requires a N.C. contact. If MTS is not used, install a jumper across terminals 4 & 5. MTS is an option, no connection is needed if the option is not ordered.
- 7 No connection

Note: The conductor colors are reference to the optional cables available from Omron STI.

Select models are available for Rapid Delivery.

Visit this product on www.sti.com for details.



Ordering

Model	Number of Beams	Overall Height
Perimeter Access PA4600		
PA46-1-000-Q2-NO1-PN	1	231.6 mm (9.12 in.)
PA46-2-500-Q2-NO1-PN	2	731.6 mm (28.80 in.)
PA46-2-600-Q2-NO1-PN	2	831.6 mm (32.74 in.)
PA46-3-400-Q2-NO1-PN	3	1031.6 mm (40.61 in.)
PA46-3-500-Q2-NO1-PN	3	1231.6 mm (48.49 in.)
PA46-4-300-Q2-NO1-PN	4	1131.6 mm (44.55 in.)
PA46-5-300-Q2-NO1-PN	5	1431.6 mm (56.36 in.)
PA46-6-300-Q2-NO1-PN	6	1731.6 mm (68.17 in.)

Accessories (sold separately)

Part Number	Description
Transmitter Cables	
CBL-LCTX-10M	Transmitter Cable, 10 m (32.8 ft)
CBL-LCTX-15M	Transmitter Cable, 15 m (49.3 ft)
CBL-LCTX-30M	Transmitter Cable, 30 m (98.5 ft)
PMC-PA46TX	M12 Transmitter Connector
Receiver Cables	
CBL-LCRX-10M	Receiver Cable, 10 m (32.8 ft)
CBL-LCRX-15M	Receiver Cable, 15 m (49.3 ft)
CBL-LCRX-30M	Receiver Cable, 30 m (98.5 ft)
PMC-PA46RX	M12 Receiver Connector
Explosion Proof Enclosures	
PA4600-EPKT-0300	350 mm protected height enclosure, each
PA4600-EPKT-0600	520 and 610 mm Protected Height Enclosure, each
PA4600-EPKT-0900	870 mm Protected Height Enclosure, each
PA4600-EPKT-1200	1215 mm Protected Height Enclosure, each
Resource Modules	
RM-1	RM-1 Resource Module
RM-2	RM-2 Resource Module
RM-2AC	RM-2AC Resource Module/Power Supply
RM-2AC-IP	RM-2AC-IP Resource Module/Power Supply
RM-3	RM-3 Resource Mute Module
RM-X	RM-X Safety Relay, 22.5 mm DIN enclosure



For information on Resource Modules, see page D-63



For information on safety light curtain accessories, see page D-78

Safety Standards and Precautions

The PA4600 is a presence sensing device used only for perimeter access guarding applications, such as around robots and workcells. The PA4600 meets ANSI/RIA R15.06-1999 (R2009) and EN999:1998 optical configuration requirements for perimeter access guarding presence-sensing devices. PA4600 systems have been EC type examined to the requirements of IEC 61496-1, -2 for a Type 4 ESPE. The PA4600 also meets the control reliability requirements of ANSI/RIA R15.06-1999 (R2009).

The optical design and detection capability of the PA4600 are optimized for torso detection of personnel entering a hazardous area from the perimeter, also called perimeter access guarding. It is not intended to be used for the detection of hands and fingers. It is not designed for, nor should it be used as, a high-resolution point-of-operation safety light curtain. The safety beams have been positioned to meet ANSI/RIA R15.06-1999 (R2009) and EN999:1998 perimeter guarding requirements. These documents are an excellent reference for the application of perimeter guarding optical devices such as the PA4600.

The PA4600 should only be used on machinery that can consistently and immediately stop anywhere in its cycle or stroke. Never use a PA4600 to guard the perimeter of a full revolution clutched power press or machine. If the PA4600 does not protect all access to the hazardous area, other appropriate devices such as mechanical guards must guard the unprotected access.

The purchaser, installer and employer have the responsibility to meet all local, state and federal government laws, rules, codes or regulations relating to the proper use, installation, operation and maintenance of this control and the guarded machine. See the Installation and Operation Manual for additional information.

All application examples described are for illustration purposes only. Actual installations will differ from those indicated.

 Select models are available for Rapid Delivery.

Visit this product on www.sti.com for details.